

# BISON

## REFRIGERATION

Includes 1 Year Parts + Labor / 5 Year Compressor Warranty

### XRR-21 1 Door Stainless Reach-In Refrigerator

#### Dimensions

Exterior Dimensions (Inches)	29" x 32.2" x 82.4"
Capacity (cu. ft.)	21 cu. ft.
Ship Weight (lbs)	322 lbs

#### Construction

Exterior Material	430 series stainless steel
Interior Material	Plastic
Insulation Material	Polyurethane
Insulation Thickness (mm)	60
# of Doors	1
# of Shelves	3
Shelf Material	Plastic coated steel
Shelf Load Capacity (lbs/pc)	155 lbs
Plug Type	NEMA 5-15P
cETLus	
NSF	

#### Cooling

Temperature Range	33° ~ 40° F
Refrigerant	R-290
Refrigerant Amount (oz)	9.2
Maximum Ambient Temperature Rating	90° F
Defrost Method	Air Defrost
Defrost Power (W)	0
Cooling Method	Ventilated
Temperature Controller	Digital
Compressor H/P	1/4

#### Electrical

Voltage (v/Hz)	115/60
Power (W)	365
Power Consumption (kw/24hr)	2
Phase	1

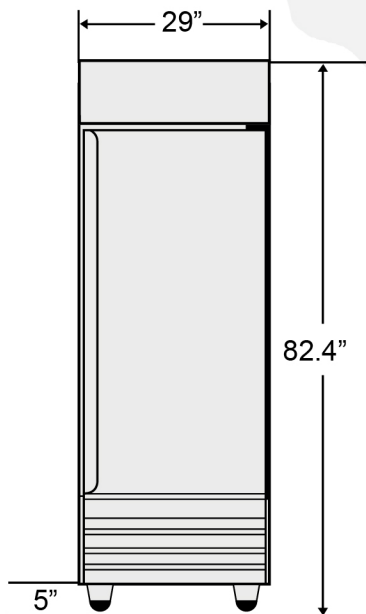

Front View

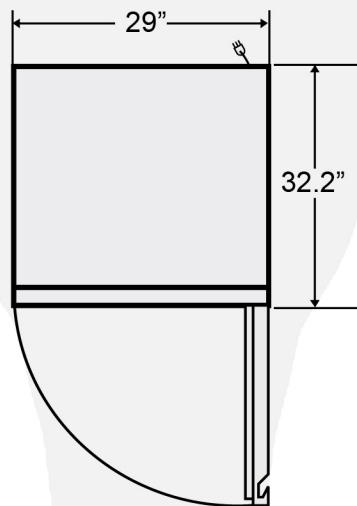

Top View

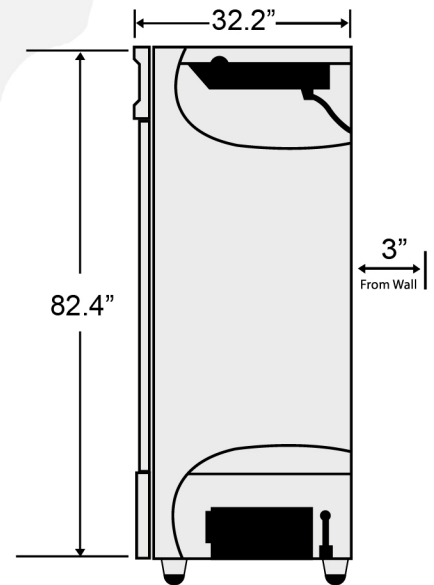

Side View

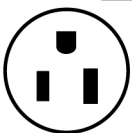

NEMA 5-15P



COMPLIES WITH ANSI/NSF 7 FOR FOOD SERVICE