

BISON

REFRIGERATION

Includes 1 Year Parts + Labor / 5 Year Compressor Warranty

XRF-46 2 Door Stainless Reach-In Freezer

Dimensions

Exterior Dimensions (Inches)	54" x 32.2" x 82.4"
Capacity (cu. ft.)	46 cu. ft.
Ship Weight (lbs)	531 lbs
Interior Dimensions	49.5" x 27" x 60.25"

Construction

Exterior Material	430 series stainless steel
Interior Material	Plastic
Insulation Material	Polyurethane
Insulation Thickness (mm)	60
# of Doors	1
# of Shelves	6
Shelf Material	Plastic coated steel
Shelf Load Capacity (lbs/pc)	155 lbs
Plug Type	NEMA 5-15P
cETLus	
NSF	

Cooling

Temperature Range	-8° ~ -1° F
Refrigerant	R-404A
Refrigerant Amount (oz)	19.4
Maximum Ambient Temperature Rating	90° F
Defrost Method	Electric Defrost
Defrost Power (W)	0
Cooling Method	Ventilated
Temperature Controller	Digital
Compressor H/P	3/4

Electrical

Voltage (v/Hz)	115/60
Power (W)	590
Power Consumption (kw/24hr)	10
Phase	1

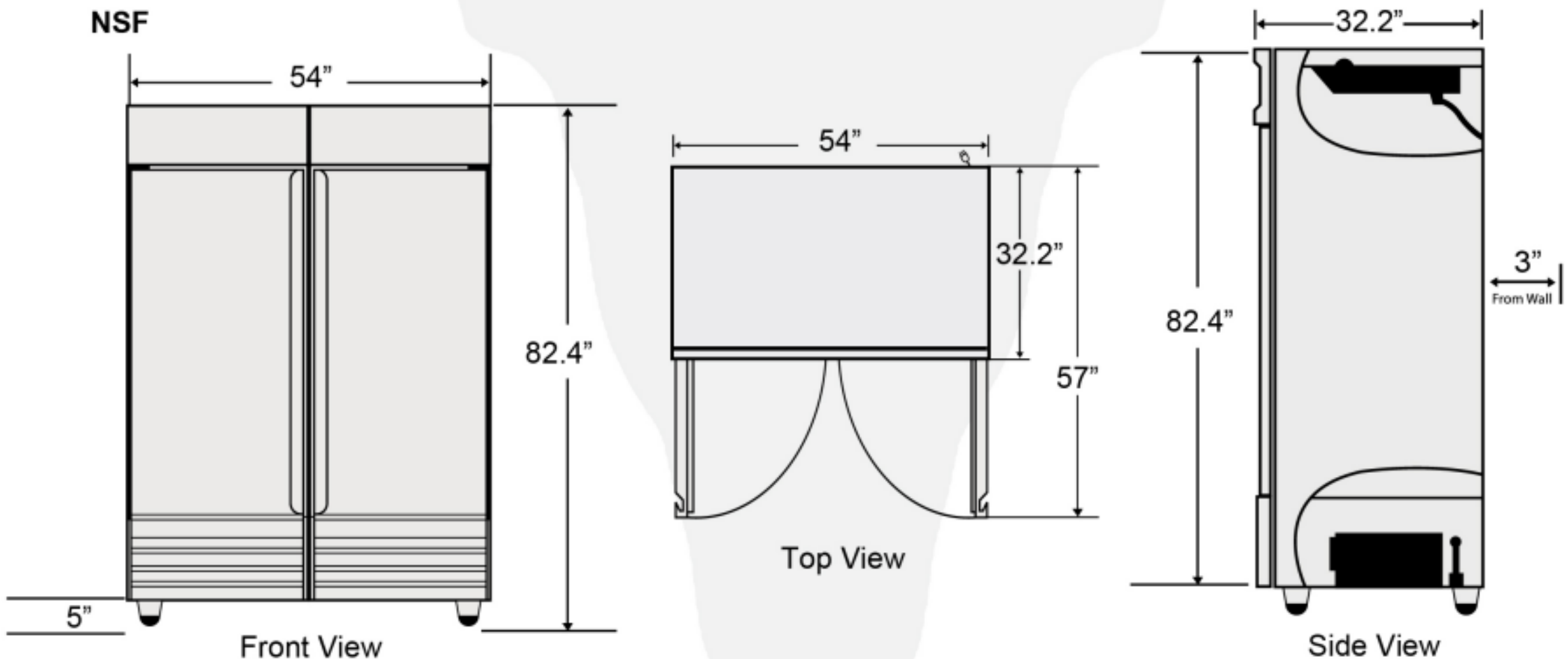

NEMA 5-15P



COMPLIES WITH ANSI/NSF 7 FOR FOOD SERVICE