



STF-47 2 DOOR REACH-IN FREEZER

UNITS MANUFACTURED PRIOR 10-1-18

INCLUDE 1 YEAR PARTS + LABOR / 5 YEAR COMPRESSOR WARRANTY

UNITS MANUFACTURED AFTER 10-1-18

INCLUDE 2 YEAR PARTS + LABOR / 5 YEAR COMPRESSOR WARRANTY

Dimensions

Exterior Dimensions (WxDxH)	54" x 32.25" x 82.5"
Interior Dimensions (WxDxH)	49.5" x 27" x 60.25"
Net Volume (cu. ft.)	46.5 cu. ft.
Gross Weight	542 lbs
Packaging Dimensions (WxDxH)	55" x 34" x 84.5"

Cooling

Temperature Range	-7.5° - 0° F
Refrigerant	R290
Maximum Ambient Temperature Rating	90° F
Defrosting	Automatic
Temperature Display	Yes
Temperature Controller	Digital
H/P	3/4

Construction

Exterior Material	430 series stainless steel
Interior Material	304 series stainless steel
Insulation Material	Foamed in place polyurethane
Shelf Material	Plastic coated steel
Shelf Load Capacity	120 lbs

Electrical

Voltage	120
Amps	10.1
Hz	60
Phase	1

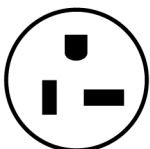
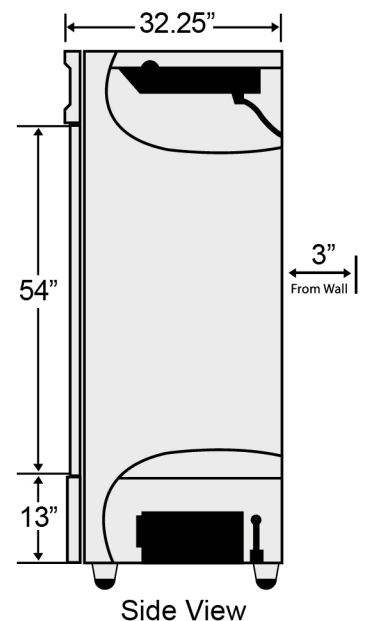
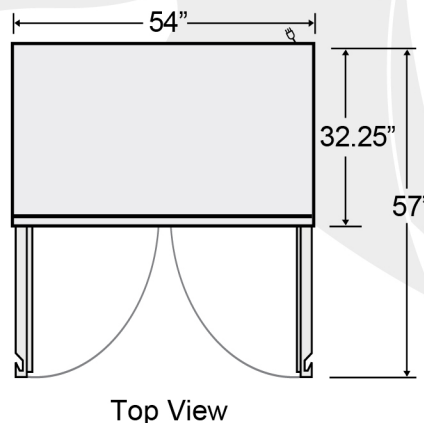
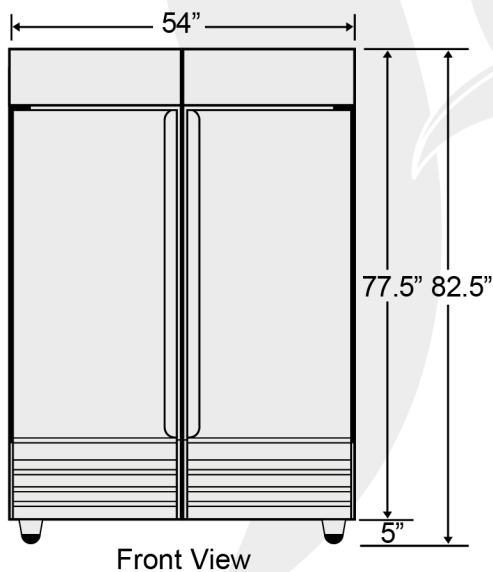

NEMA 5-20



COMPLIES WITH ANSI/NSF 7 FOR FOOD SERVICE