



SST-48-18 2 DOOR MEGA TOP SANDWICH/SALAD PREP REFRIGERATOR

UNITS MANUFACTURED PRIOR 10-1-18
 INCLUDE 1 YEAR PARTS + LABOR / 5 YEAR COMPRESSOR WARRANTY

UNITS MANUFACTURED AFTER 10-1-18
 INCLUDE 2 YEAR PARTS + LABOR / 5 YEAR COMPRESSOR WARRANTY

Dimensions

Exterior Dimensions (WxDxH)	46.75" x 34" x 46.25"
Interior Dimensions Top (WxDxH)	42.5" x 21.5" x 8.5"
Interior Dimensions Bottom (WxDxH)	43" x 19.5" x 20"
Cutting Board Dimensions (WxDxH)	46.75" x 7.0" x .75"
Net Volume (cu. ft.)	9.75 cu. ft.
Gross Weight	370 lbs
Packaging Dimensions (WxDxH)	51.5" x 38.5" x 49.5"
Electrical Cord Length	84"

Cooling

Temperature Range	33° - 40° F
Refrigerant	R290
Maximum Ambient Temperature Rating	90° F
Defrosting	Automatic
Temperature Display	Yes
Temperature Controller	Digital
H/P	1/3

Construction

Exterior Material	430 series stainless steel
Interior Material	304 series stainless steel
Insulation Material	Foamed in place polyurethane
Shelf Material	Plastic coated steel
Shelf Load Capacity	90 lbs

*Does not include pans

Electrical

Voltage	120
Amps	8.1
Hz	60
Phase	1

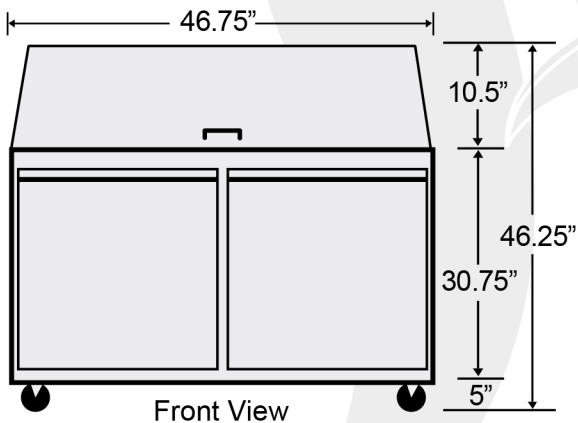

Front View

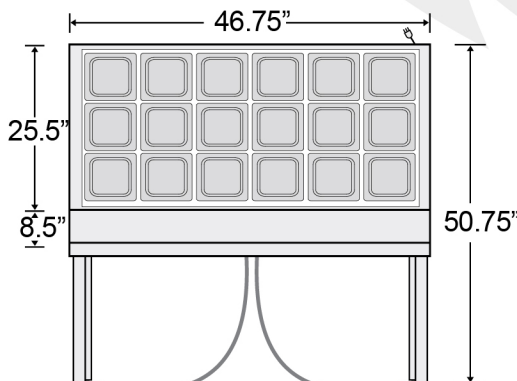

Top View

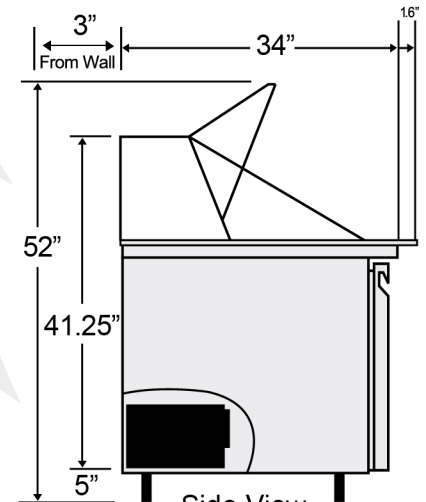

Side View

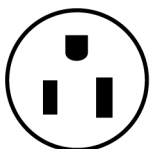

NEMA 5-15P



COMPLIES WITH ANSI/NSF 7 FOR FOOD SERVICE