



SPR-93 3 DOOR PIZZA PREP TABLE

UNITS MANUFACTURED PRIOR 10-1-18
 INCLUDE 1 YEAR PARTS + LABOR / 5 YEAR COMPRESSOR WARRANTY

UNITS MANUFACTURED AFTER 10-1-18
 INCLUDE 2 YEAR PARTS + LABOR / 5 YEAR COMPRESSOR WARRANTY

Dimensions

Exterior Dimensions (WxDxH)	92" x 31.5" x 43"
Interior Dimensions Top (WxDxH)	84.25" x 10" x 13"
Interior Dimensions Bottom (WxDxH)	69.5" x 27.5" x 23.75"
Cutting Board Dimensions (WxDxH)	91.5" x 19.5" x .79"
Net Volume (cu. ft.)	24 cu. ft.
Gross Weight	611 lbs
Packaging Dimensions (WxDxH)	96" x 36" x 47.5"

Cooling

Temperature Range	33° - 40° F
Refrigerant	R290
Maximum Ambient Temperature Rating	90° F
Defrosting	Automatic
Temperature Display	Yes
Temperature Controller	Digital
H/P	1/2

Construction

Exterior Material	430 series stainless steel
Interior Material	304 series stainless steel
Insulation Material	Foamed in place polyurethane
Shelf Material	Plastic coated steel
Shelf Load Capacity	90 lbs

*Does not include pans

Electrical

Voltage	115
Amps	11.1
Hz	60
Phase	1

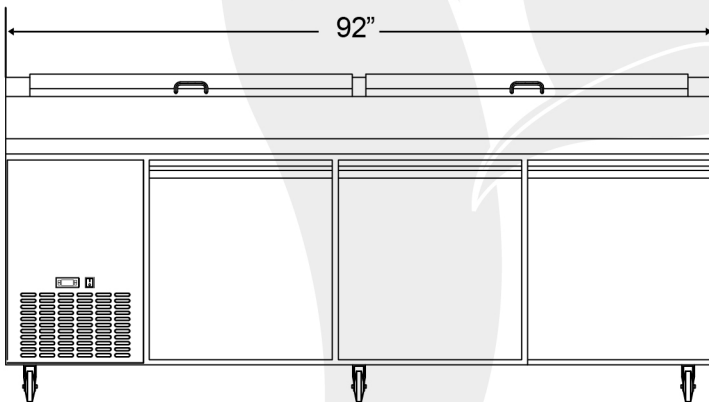

Front View

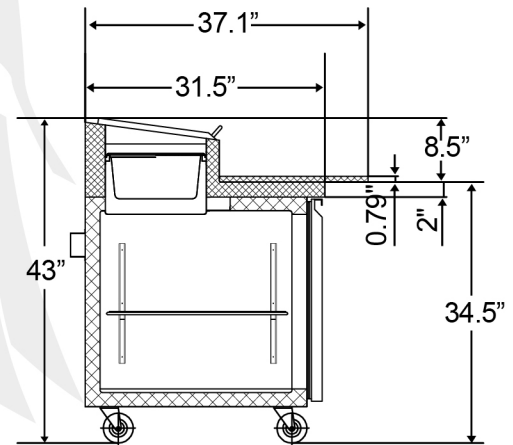

Side View

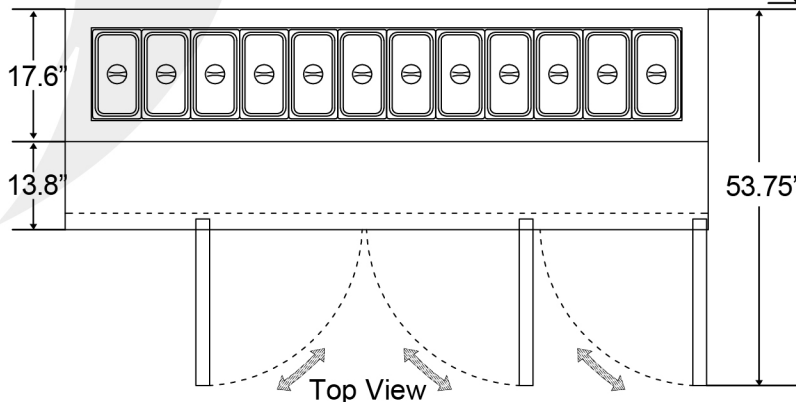

Top View

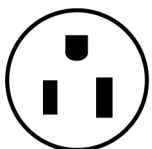

NEMA 5-15P



COMPLIES WITH ANSI/NSF 7 FOR FOOD SERVICE