



SGM-53RS 2 DOOR REACH-IN GLASS DOOR REFRIGERATOR

UNITS MANUFACTURED PRIOR 10-1-18
INCLUDE 1 YEAR PARTS + LABOR / 5 YEAR COMPRESSOR WARRANTY

UNITS MANUFACTURED AFTER 10-1-18
INCLUDE 2 YEAR PARTS + LABOR / 5 YEAR COMPRESSOR WARRANTY

Dimensions

Exterior Dimensions (WxDxH)	53 1/8" x 31 7/8" x 79 3/8"
Interior Dimensions (WxDxH)	
Net Volume (cu. ft.)	45 cu. ft.
Gross Weight	
Packaging Dimensions (WxDxH)	

Cooling

Temperature Range	33° - 40° F
Refrigerant	R290
Maximum Ambient Temperature Rating	90° F
Defrosting	Automatic
Temperature Display	Yes
Temperature Controller	Digital
H/P	1/4+

Construction

Exterior Material	Painted steel
Door/Lid Material	Glass Door
Insulation Material	Foamed in place polyurethane
Shelf Material	Plastic coated steel
Shelf Load Capacity	90 lbs

Electrical

Voltage	115/60/1
Amps	4.3
Hz	

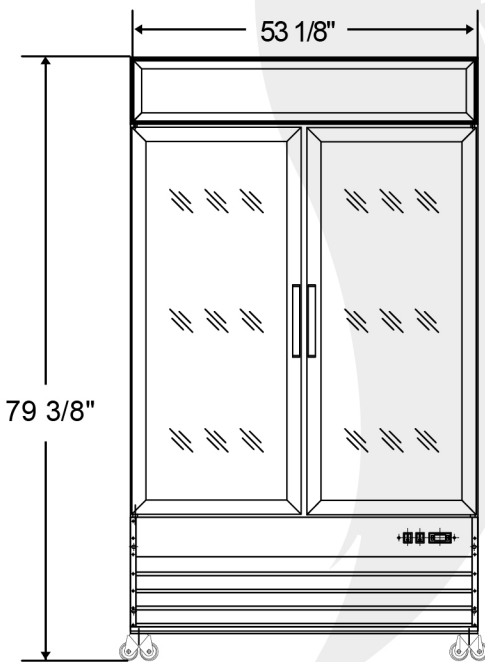

Front View

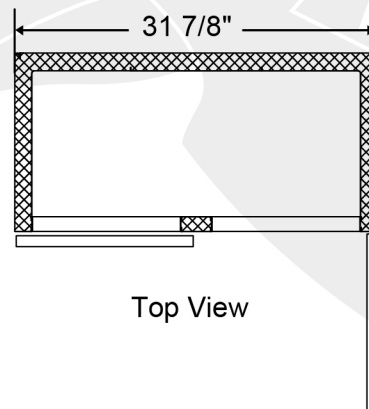

Top View

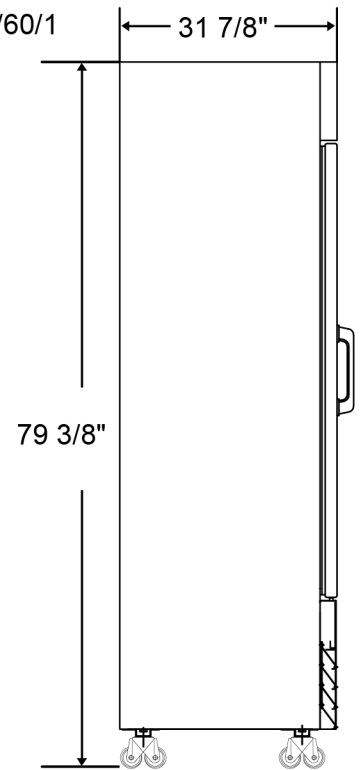

Side View



NEMA 5-15P



COMPLIES WITH ANSI/NSF 7 FOR FOOD SERVICE