



KUR-72

**INCLUDES 1 YEAR PARTS + LABOR/ 5 YEAR
COMPRESSOR WARRANTY
STAINLESS STEEL WORKTOP REFRIGERATOR**

Dimensions

Exterior Dimensions (Inches)	72.75" x 30" x 37.25"
Interior Dimensions (Inches)	69" x 24" x 24"
Packaging Dimensions (Inches)	75.4" x 33.5" x 37.7"
Capacity (cu. ft.)	23 cu. ft.
Gross Weight (lbs)	353 lbs

Construction

Exterior Material	430 series stainless steel
Interior Material	Plastic Coated
Insulation Material	Polyurethane
Insulation Thickness (mm)	45
# of Doors	3
# of Shelves	3
Shelf Material	Plastic coated steel
Shelf Load Capacity (lbs/pc)	155 lbs

Cooling

Temperature Range	33° ~ 40° F
Refrigerant	R290
Refrigerant Amount (oz)	11.6
Maximum Ambient Temperature Rating	90° F
Defrost Method	Air Defrost
Defrost Power (W)	500
Cooling Method	Ventilated
Temperature Controller	Thermostat
Compressor H/P	1/3

Electrical

Voltage (v/Hz)	115/60
Power (W)	390
Power Consumption (kw/24hr)	1.7
Phase	1

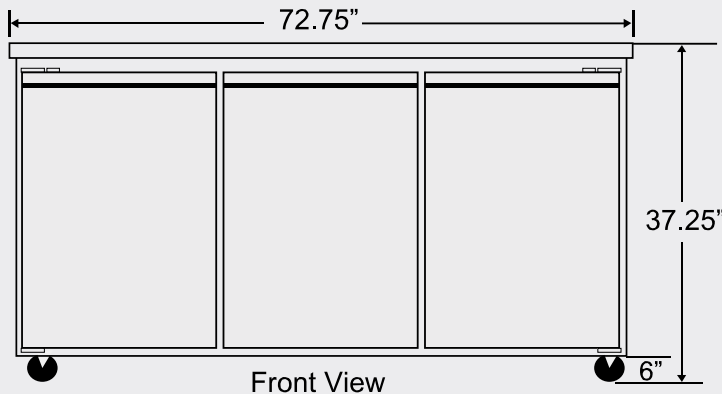

Front View

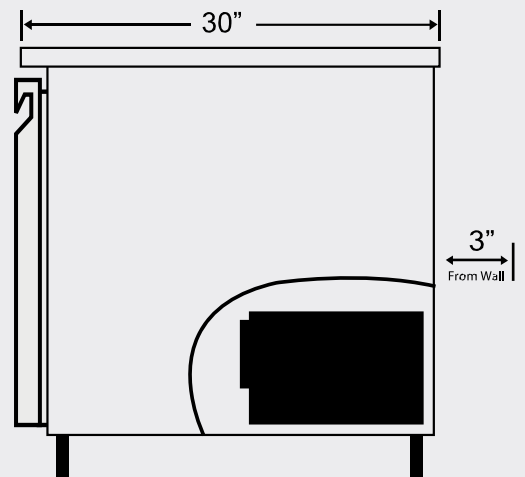

Side View

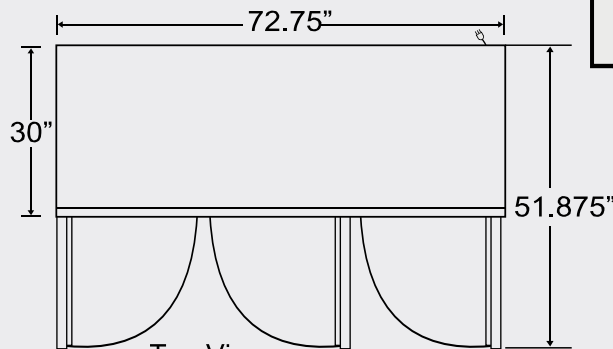

Top View



NEMA 5-15P

