



KST-72

**INCLUDES 1 YEAR PARTS + LABOR/ 5 YEAR
COMPRESSOR WARRANTY
STAINLESS STEEL SANDWICH UNIT**

Dimensions

Exterior Dimensions (Inches)	72.75" x 30" x 43.75"
Interior Dimensions Top (Inches)	66.25" x 12.75" x 7"
Interior Dimensions Bottom (Inches)	69" x 24" x 28"
Packaging Dimensions (Inches)	75.4" x 33.5" x 45.9"
Capacity (cu. ft.)	19 cu. ft.
Gross Weight (lbs)	375 lbs

Construction

Exterior Material	430 series stainless steel
Interior Material	Plastic Coated
Insulation Material	Polyurethane
Insulation Thickness (mm)	45
# of Doors	3
# of Shelves	3
Shelf Material	Plastic coated steel
Shelf Load Capacity (lbs/pc)	155 lbs

*Does not include pans

Cooling

Temperature Range	33° ~ 40° F
Refrigerant	R290
Refrigerant Amount (oz)	17.6
Maximum Ambient Temperature Rating	90° F
Defrost Method	Air Defrost
Defrost Power (W)	0
Cooling Method	Ventilated
Temperature Controller	Thermostat
Compressor H/P	1/2

Electrical

Voltage (v/Hz)	115/60
Power (W)	630
Power Consumption (kw/24hr)	2.6
Phase	1

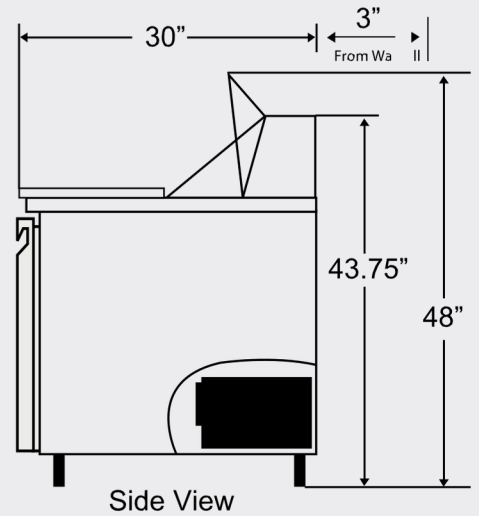
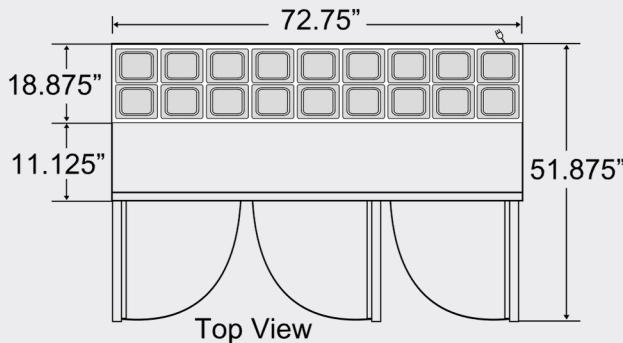
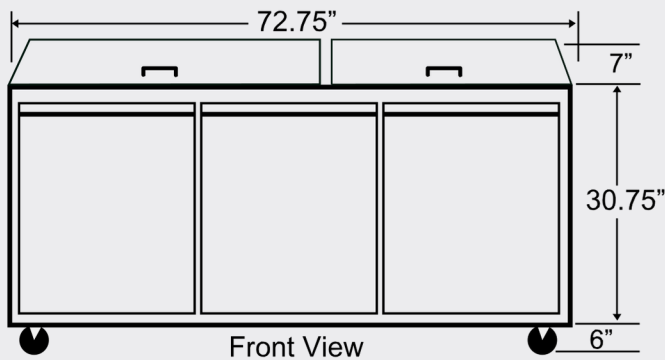

NEMA 5-15P

