



KST-72-30

**INCLUDES 1 YEAR PARTS + LABOR/ 5 YEAR
COMPRESSOR WARRANTY**

STAINLESS STEEL MEGATOP SANDWICH UNIT

Dimensions

Exterior Dimensions (Inches)	72.75" x 34" x 47.25"
Interior Dimensions Top (Inches)	67.55" x 20.5" x 10"
Interior Dimensions Bottom (Inches)	69" x 24" x 28"
Packaging Dimensions (Inches)	75.4" x 37.5" x 48.2"
Capacity (cu. ft.)	22.6 cu. ft.
Gross Weight (lbs)	397 lbs

Construction

Exterior Material	430 series stainless steel
Interior Material	Plastic Coated
Insulation Material	Polyurethane
Insulation Thickness (mm)	45
# of Doors	3
# of Shelves	3
Shelf Material	Plastic coated steel
Shelf Load Capacity (lbs/pc)	155 lbs

*Does not include pans

Cooling

Temperature Range	33° ~ 40° F
Refrigerant	R290
Refrigerant Amount (oz)	17.6
Maximum Ambient Temperature Rating	90° F
Defrost Method	Air Defrost
Defrost Power (W)	0
Cooling Method	Ventilated
Temperature Controller	Thermostat
Compressor H/P	1/2

Electrical

Voltage (v/Hz)	115/60
Power (W)	630
Power Consumption (kw/24hr)	2.6
Phase	1

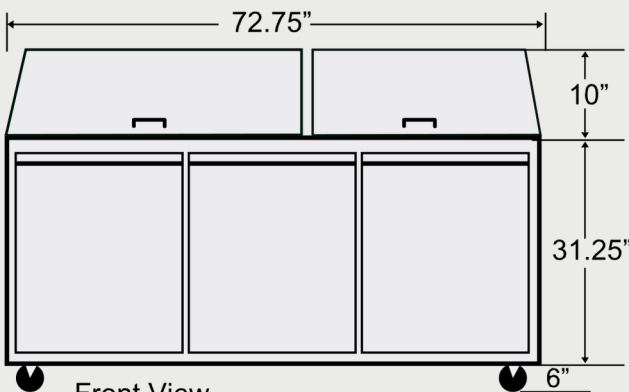

Front View

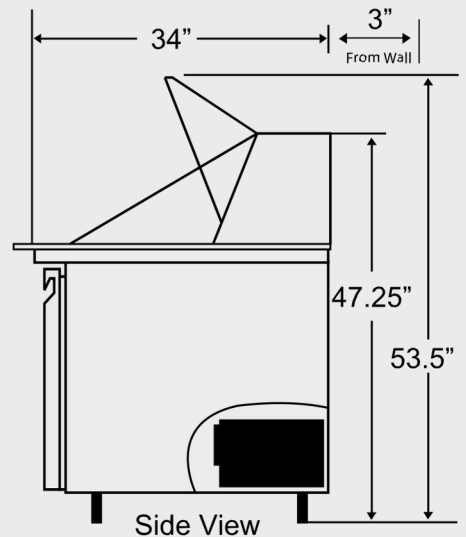

Side View

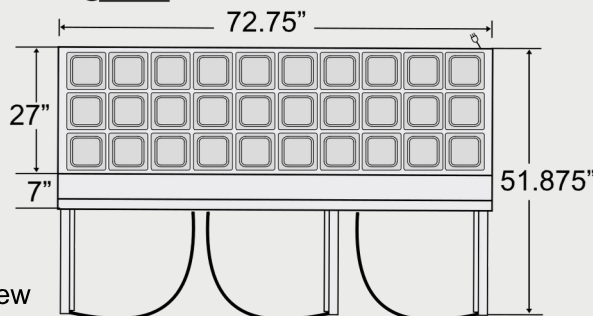

Top View



NEMA 5-15P

