



KST-60-24

**INCLUDES 1 YEAR PARTS + LABOR/ 5 YEAR
COMPRESSOR WARRANTY
STAINLESS STEEL MEGATOP SANDWICH UNIT**

Dimensions

Exterior Dimensions (Inches)	60.25" x 34" x 47.25"
Interior Dimensions Top (Inches)	54.75" x 20.5" x 10"
Interior Dimensions Bottom (Inches)	57" x 24" x 26"
Packaging Dimensions (Inches)	63" x 37.5" x 48.2"
Capacity (cu. ft.)	18.6 cu. ft.
Gross Weight (lbs)	353 lbs

Construction

Exterior Material	430 series stainless steel
Interior Material	Plastic Coated
Insulation Material	Polyurethane
Insulation Thickness (mm)	45
# of Doors	2
# of Shelves	2
Shelf Material	Plastic coated steel
Shelf Load Capacity (lbs/pc)	155 lbs

*Does not include pans

Cooling

Temperature Range	33° ~ 40° F
Refrigerant	R290
Refrigerant Amount (oz)	12.3
Maximum Ambient Temperature Rating	90° F
Defrost Method	Air Defrost
Defrost Power (W)	0
Cooling Method	Ventilated
Temperature Controller	Thermostat
Compressor H/P	1/2

Electrical

Voltage (v/Hz)	115/60
Power (W)	560
Power Consumption (kw/24hr)	2.2
Phase	1

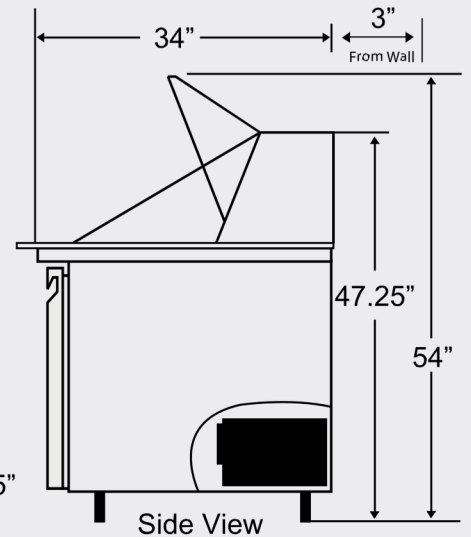
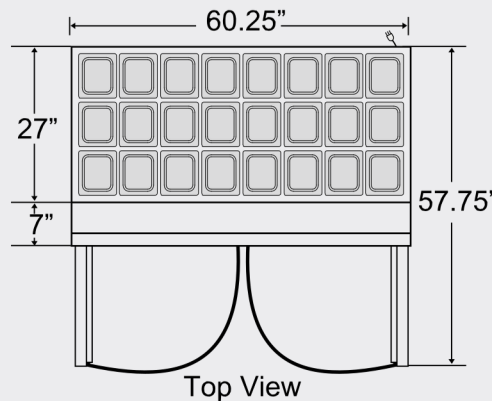
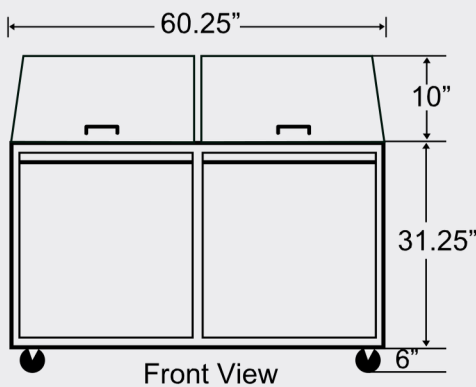

NEMA 5-15P

