



KST-48

**INCLUDES 1 YEAR PARTS + LABOR/ 5 YEAR
COMPRESSOR WARRANTY
STAINLESS STEEL SANDWICH UNIT**

Dimensions

Exterior Dimensions (Inches)	48.25" x 30.125" x 44.75"
Interior Dimensions Top (Inches)	42.5" x 21.5" x 8.5"
Interior Dimensions Bottom (Inches)	43" x 19.5" x 20"
Packaging Dimensions (Inches)	51" x 33.5" x 45.9"
Capacity (cu. ft.)	12 cu. ft.
Gross Weight (lbs)	242 lbs

Construction

Exterior Material	430 series stainless steel
Interior Material	Plastic Coated
Insulation Material	Polyurethane
Insulation Thickness (mm)	45
# of Doors	2
# of Shelves	2
Shelf Material	Plastic coated steel
Shelf Load Capacity (lbs/pc)	155 lbs

*Does not include pans

Cooling

Temperature Range	33° ~ 40° F
Refrigerant	R290
Refrigerant Amount (oz)	12.3
Maximum Ambient Temperature Rating	90° F
Defrost Method	Air Defrost
Defrost Power (W)	0
Cooling Method	Ventilated
Temperature Controller	Thermostat
Compressor H/P	1/3

Electrical

Voltage (v/Hz)	115/60
Power (W)	560
Power Consumption (kw/24hr)	2.2
Phase	1

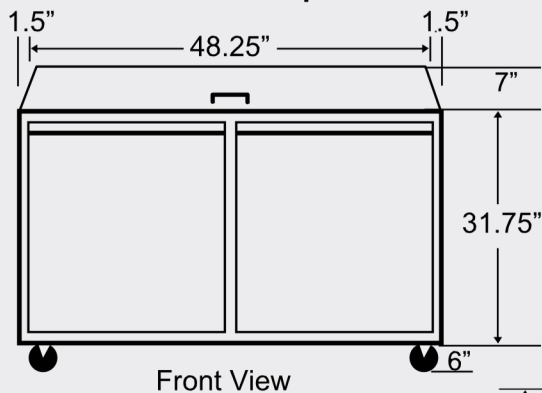

Front View

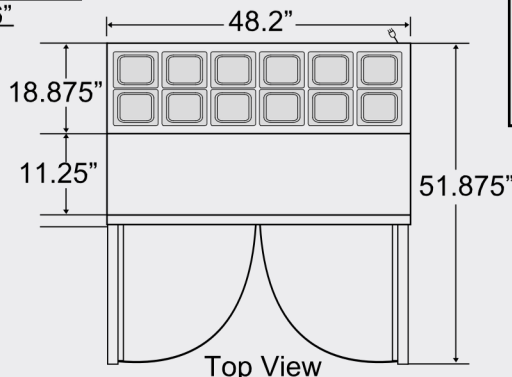

Top View

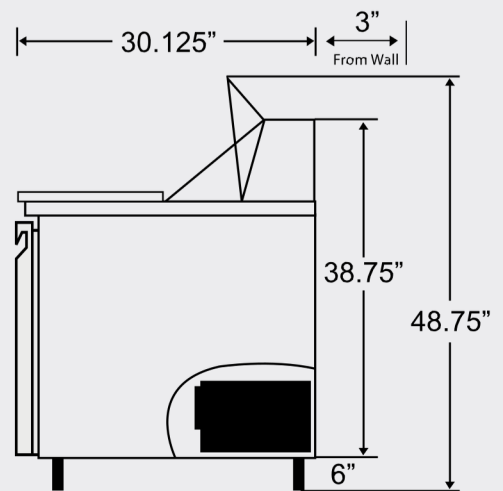

Side View



NEMA 5-15P

