



KST-27

**INCLUDES 1 YEAR PARTS + LABOR/ 5 YEAR
COMPRESSOR WARRANTY
STAINLESS STEEL SANDWICH UNIT**

Dimensions

Exterior Dimensions (Inches)	27.5" x 30" x 44.25"
Interior Dimensions (Inches)	24" x 24" x 24"
Packaging Dimensions (Inches)	30.2" x 33.5" x 45.9"
Capacity (cu. ft.)	6.5 cu. ft.
Gross Weight (lbs)	199 lbs

Construction

Exterior Material	430 series stainless steel
Interior Material	Plastic Coated
Insulation Material	Polyurethane
Insulation Thickness (mm)	45
# of Doors	1
# of Shelves	1
Shelf Material	Plastic coated steel
Shelf Load Capacity (lbs/pc)	155 lbs
*Does not include pans	

Cooling

Temperature Range	33° ~ 40° F
Refrigerant	R290
Refrigerant Amount (oz)	9.2
Maximum Ambient Temperature Rating	90° F
Defrost Method	Air Defrost
Defrost Power (W)	0
Cooling Method	Ventilated
Temperature Controller	Thermostat
Compressor H/P	1/4

Electrical

Voltage (v/Hz)	115/60
Power (W)	390
Power Consumption (kw/24hr)	1.6
Phase	1

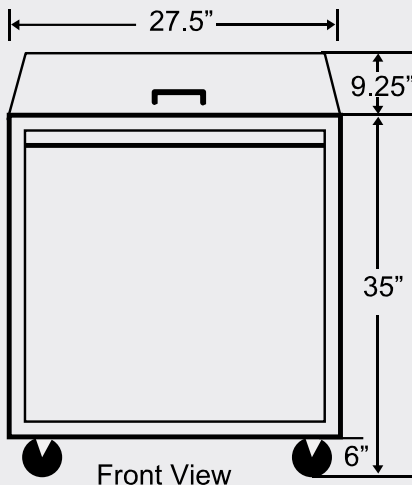

Front View

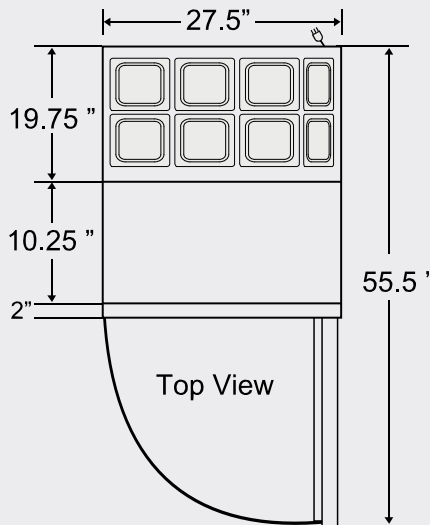

Top View

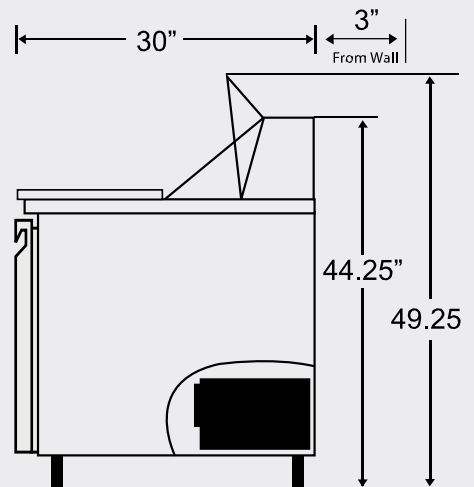

Side View



NEMA 5-15P



COMPLIES WITH ANS/NSF 7 FOR FOOD SERVICE