



KST-27-12

**INCLUDES 1 YEAR PARTS + LABOR/ 5 YEAR  
COMPRESSOR WARRANTY**

**STAINLESS STEEL MEGATOP SANDWICH UNIT**

**Dimensions**

Exterior Dimensions (Inches)	27.5" x 34" x 47.125"
Interior Dimensions (Inches)	24" x 24" x 24"
Packaging Dimensions (Inches)	30.2" x 37.5" x 48.2"
Capacity (cu. ft.)	7.9 cu. ft.
Gross Weight (lbs)	221 lbs

**Construction**

Exterior Material	430 series stainless steel
Interior Material	Plastic Coated
Insulation Material	Polyurethane
Insulation Thickness (mm)	45
# of Doors	1
# of Shelves	1
Shelf Material	Plastic coated steel
Shelf Load Capacity (lbs/pc)	155 lbs
*Does not include pans	

**Cooling**

Temperature Range	33° ~ 40° F
Refrigerant	R290
Refrigerant Amount (oz)	9.2
Maximum Ambient Temperature Rating	90° F
Defrost Method	Air Defrost
Defrost Power (W)	0
Cooling Method	Ventilated
Temperature Controller	Thermostat
Compressor H/P	1/4

**Electrical**

Voltage (v/Hz)	115/60
Power (W)	390
Power Consumption (kw/24hr)	1.6
Phase	1

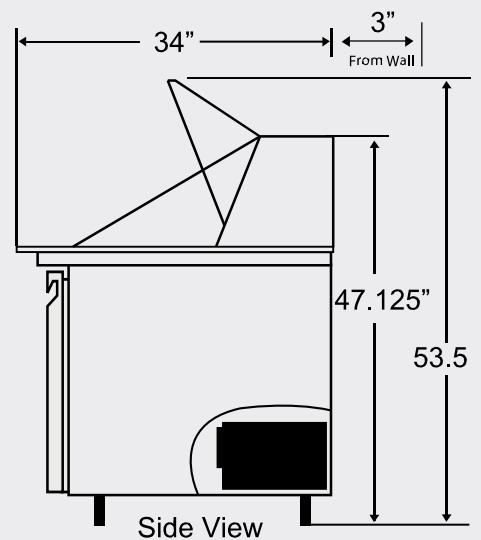
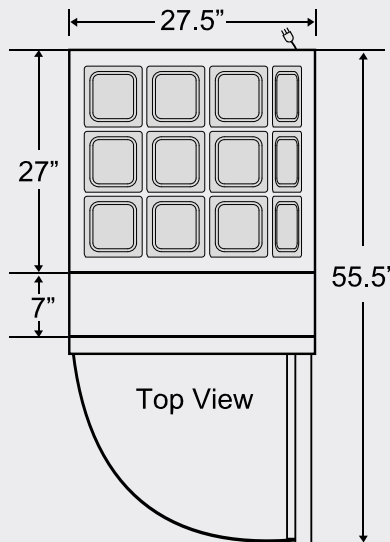
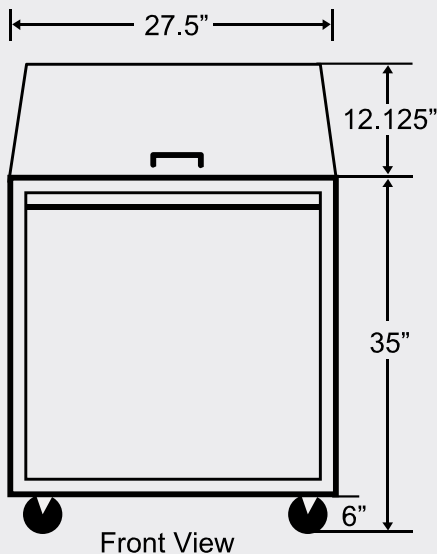

NEMA 5-15P

