



KRF-21

**INCLUDES 1 YEAR PARTS + LABOR/ 5 YEAR
COMPRESSOR WARRANTY
STAINLESS STEEL REACH-IN FREEZER**

Dimensions

Exterior Dimensions (Inches)	29" x 32.2" x 82.4"
Interior Dimensions (Inches)	24.5" x 27" x 60.25
Packaging Dimensions (Inches)	28.7" x 33.1" x 88.5"
Capacity (cu. ft.)	21 cu. ft.
Gross Weight (lbs)	322 lbs

Construction

Exterior Material	430 series stainless steel
Interior Material	Plastic Coated
Insulation Material	Polyurethane
Insulation Thickness (mm)	60
# of Doors	1
# of Shelves	3
Shelf Material	Plastic coated steel
Shelf Load Capacity (lbs/pc)	155 lbs

Cooling

Temperature Range	-8° ~ -1° F
Refrigerant	R290
Refrigerant Amount (oz)	13.4
Maximum Ambient Temperature Rating	90° F
Defrost Method	Electric Defrost
Defrost Power (W)	630
Cooling Method	Ventilated
Temperature Controller	Digital
Compressor H/P	1/2

Electrical

Voltage (v/Hz)	115/60
Power (W)	650
Power Consumption (kw/24hr)	6.2
Phase	1

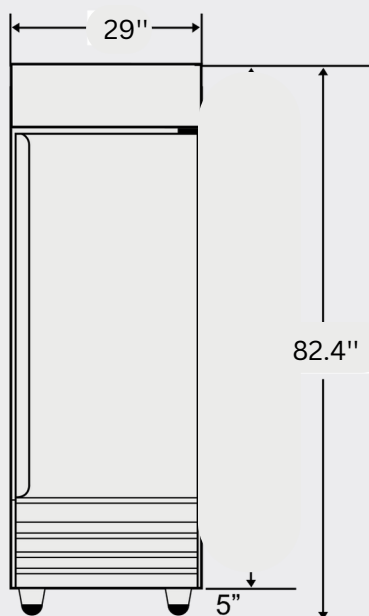

Front View

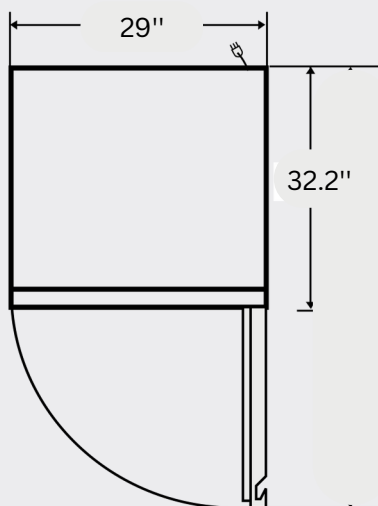

Top View

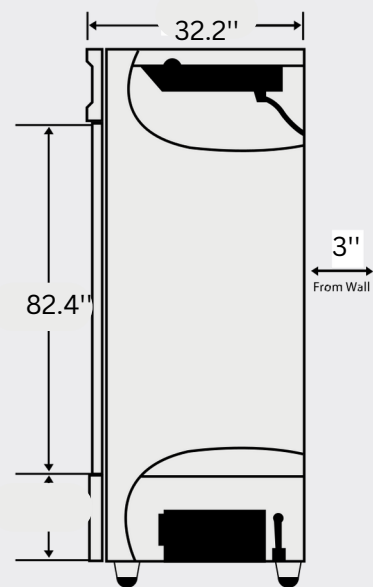

Side View



NEMA 5-15P



COMPLIES WITH ANSI/NSF 7 FOR FOOD SERVICE